

Metal pails for packaging liquid content of viscosity in excess of 200 mm²/s and solid, powdered and pasty materials



Conical pails (0A2 type) with detachable lug lid and one bead, manufactured from electrolytic tinplate coated with tin. The pails are manufactured by the process of welding the longitudinal seam and by sealing the bottom, applying new production technologies in line with good production practices, respecting the specific demands of the customer.

The outside of the pail is not lacquer coating or coated with white lacquer, with or without lithographic print, as per customer specifications.

Optional protective lacquer coating on the inside.

RID/ADR approval symbol and designation of sheet metals used embossed on the bottom.

*Top product quality
demands top quality
packing cans*

*Can quality and customer
satisfaction come first*

Pail quality

Protection of the pail's external weld.

The quality of raw materials sourced and of the finished product is guaranteed through cooperation with trusted suppliers and physical and chemical analyses of the raw materials sourced and of the finished product in our internal laboratory.

We apply process and finished product quality control of pails by standardised testing methods to check seam permeability and the body to pail bottom seam.

Product traceability throughout the entire manufacturing process, *from sheet to pail.*

New product development

In collaboration with customers and applying new technologies and tools we are able to develop pails of various shapes and sizes.

*Steel does not lose its
attributes during recycling.*

*Steel recycling contributes
to the preservation of the
natural environment.*



LimSamobor

METAL PAILS

TECHNICAL SPECIFICATION

Nominal pail dimension [mm]	Pail height [mm]	Nominal Volume [L]
ø292 / ø275 x "H"	230	10
	298	15
	330	18
	346	19
	356	20
	386	23

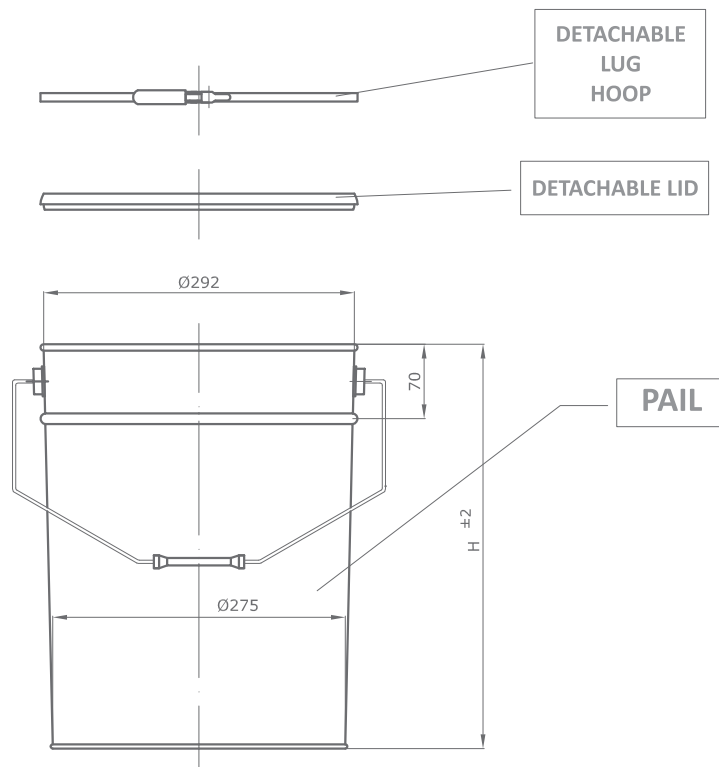

LimSamobor

From sheet to pail